

**Key**

- ① — Decothane Top Coat as per Sika Liquid Plastics Project Specification
- ② — Decothane Base Coat with embedded Reemat Premium GFM
- ③ — Existing rolled lead sheet prepared and primed in strict accordance with Sika Liquid Plastics Project Specification
- ④ — 50mm Low-tack masking/debonding tape applied centrally to the movement joint
- ⑤ — Decothane Base Coat embedded with 150mm Heavy Duty Flexitape
- ⑥ Typical lead roll joint with wood core; nominal 40mm splash lap

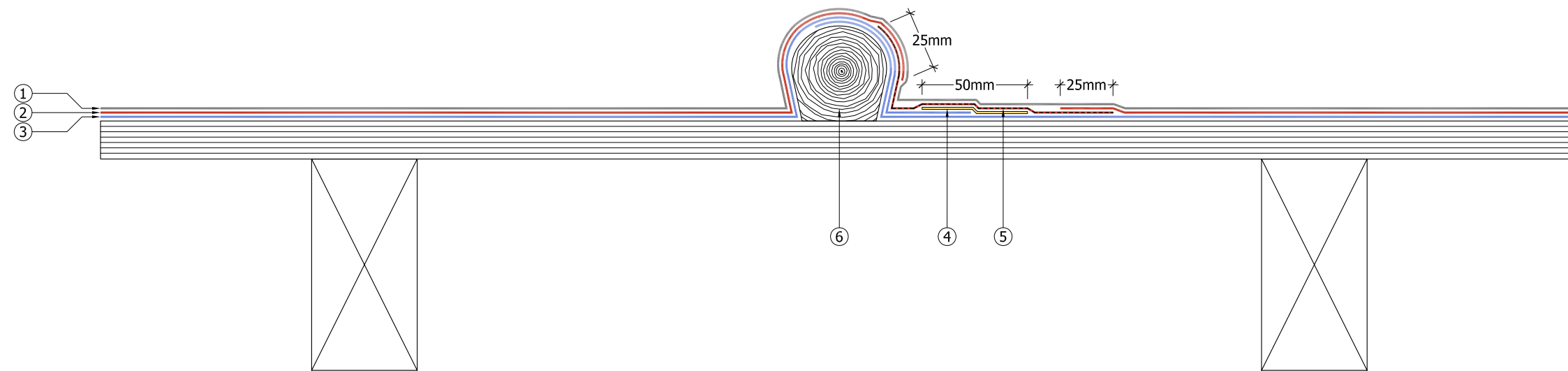

**Bond Break - Metal Roof Sheets and Metal Gutter Joints:** In order to accommodate thermal expansion and contraction at joints in Metal Roof Sheets or Metal Gutters and prior to applying the waterproofing membrane, a 'bond break' should be introduced at each joint by first laying 50mm (minimum width) low tack debonding tape centred on the joint. Follow by applying a full stripe-coat of Decothane Base Coat, approximately 200mm wide, and whilst wet, insert 150mm Heavy Duty Reemat Flexitape into the wet membrane by gentle pressure from a loaded brush, thus applying further material until the tape is obliterated. Allow to dry before continuing with the top coats.

**Note:** This treatment should ideally be carried out whilst the sheets are in contraction, i.e. prior to being exposed to increasing temperatures. Cool periods of the day are better, early mornings or later in an evening, out of direct sunlight.

**Tape Tension:** Embed Reemat Flexitape into the wet membrane without tension or stretching of the tape. Lay the tape as naturally as possible, direct from the roll, inner face upwards in order to avoid edge curl.



Sika Liquid Plastics  
 Sika House  
 Miller Street  
 Preston  
 Lancashire PR1 1EA  
 Telephone: 01772 259781  
 Email: technical.customer.services@uk.sika.com  
 Web: www.liquidplastics.co.uk

This drawing is solely intended to illustrate the correct application of Sika Liquid Plastics products and systems, it must be read in conjunction with the appropriate specification and current issue of relevant Technical Data Sheets. All elements bearing reference to structural and/or thermal design are shown indicatively and should not be used in whole or in part for any aspect of project design without consulting the relevant authorities.

For refurbishment projects, all aspects of the existing roof are deemed to be fully compliant with BS 6229:2003 (Code of Practice for Flat Roofs with Continuously Supported Coverings) or improved upon for instances where these standards are not met.

Site-specific details not covered by our range of Standard Details can be obtained by providing relevant information to the email address shown.

Project No:

DWG No: Revision

Project:

Drawing Title:  
 Waterproofing Sequencing Build-Up  
 Bond Break detail to a lead sheet  
 roof roll with a timber core

Scale: NTS @ A3 Drawn:

Date:

